

RUSDUN FARMS, LLC, CERTIFICATE OF OWNERSHIP AND DEDICATION

I, _____, the undersigned owner of the property shown hereon, hereby adopt this plan of subdivision with my free consent and dedicate the streets, easements, rights-of-way, rights of access as shown and all utilities to the City of Piperton forever, and hereby certify that I am the owner in fee simple, duly authorized so the act, and that said property is unencumbered by any taxes that have become due and payable.

Owner _____ Date _____

NOTARY'S CERTIFICATE

State of Tennessee
County of Fayette

Before me, the undersigned, a notary public in and for the State and County aforesaid, duly commissioned and qualified, personally appeared _____ with whom I am personally acquainted and who, upon oath, acknowledged himself to be owner of the property as shown herein and he as such owner, executed the foregoing instrument for the purpose therein contained. In witness whereof, I hereunto set my hand and affix my seal this, the ____ day of _____, 20__.

Notary Public

My Commission expires: _____

MORTGAGEE'S CERTIFICATE

We, the undersigned, _____ (printed name of mortgagee), mortgagee of the property shown, hereby agree to this plan of subdivision and dedicate the streets, rights-of-way, easements, and rights of access as shown to the public use forever, and hereby certify that we are the mortgagee duly authorized so to act and that said property is unencumbered by any taxes which have become due and payable.

Mortgagee (signature) _____ Date _____

NOTARY'S CERTIFICATE

State of Tennessee
County of Fayette

Before me, the undersigned, a notary public in and for the State and County aforesaid, duly commissioned and qualified, personally appeared _____ with whom I am personally acquainted and who, upon oath, acknowledged himself to be _____ with whom I am personally acquainted and who, upon oath, acknowledged himself to be _____ (title) of the _____ the within named bargainer, and that he executed the foregoing instrument for the purpose therein contained. In witness whereof, I hereunto set my hand and affix my seal this, the ____ day of _____, 20__.

Notary Public

My Commission expires: _____

CITY OF PIPERTON CERTIFICATE OF OWNERSHIP AND DEDICATION

I, _____, the undersigned owner of the property shown hereon, hereby adopt this plan of subdivision with my free consent and dedicate the streets, easements, rights-of-way, rights of access as shown and all utilities to the City of Piperton forever, and hereby certify that I am the owner in fee simple, duly authorized so the act, and that said property is unencumbered by any taxes that have become due and payable.

Owner _____ Date _____

NOTARY'S CERTIFICATE

State of Tennessee
County of Fayette

Before me, the undersigned, a notary public in and for the State and County aforesaid, duly commissioned and qualified, personally appeared _____ with whom I am personally acquainted and who, upon oath, acknowledged himself to be owner of the property as shown herein and he as such owner, executed the foregoing instrument for the purpose therein contained. In witness whereof, I hereunto set my hand and affix my seal this, the ____ day of _____, 20__.

Notary Public

My Commission expires: _____

MORTGAGEE'S CERTIFICATE

We, the undersigned, _____ (printed name of mortgagee), mortgagee of the property shown, hereby agree to this plan of subdivision and dedicate the streets, rights-of-way, easements, and rights of access as shown to the public use forever, and hereby certify that we are the mortgagee duly authorized so to act and that said property is unencumbered by any taxes which have become due and payable.

Mortgagee (signature) _____ Date _____

NOTARY'S CERTIFICATE

State of Tennessee
County of Fayette

Before me, the undersigned, a notary public in and for the State and County aforesaid, duly commissioned and qualified, personally appeared _____ with whom I am personally acquainted and who, upon oath, acknowledged himself to be _____ with whom I am personally acquainted and who, upon oath, acknowledged himself to be _____ (title) of the _____ the within named bargainer, and that he executed the foregoing instrument for the purpose therein contained. In witness whereof, I hereunto set my hand and affix my seal this, the ____ day of _____, 20__.

Notary Public

My Commission expires: _____

PIPERTON HILLS PHASE 1 LLC, CERTIFICATE OF OWNERSHIP AND DEDICATION

I, _____, the undersigned owner of the property shown hereon, hereby adopt this plan of subdivision with my free consent and dedicate the streets, easements, rights-of-way, rights of access as shown and all utilities to the City of Piperton forever, and hereby certify that I am the owner in fee simple, duly authorized so the act, and that said property is unencumbered by any taxes that have become due and payable.

Owner _____ Date _____

NOTARY'S CERTIFICATE

State of Tennessee
County of Fayette

Before me, the undersigned, a notary public in and for the State and County aforesaid, duly commissioned and qualified, personally appeared _____ with whom I am personally acquainted and who, upon oath, acknowledged himself to be owner of the property as shown herein and he as such owner, executed the foregoing instrument for the purpose therein contained. In witness whereof, I hereunto set my hand and affix my seal this, the ____ day of _____, 20__.

Notary Public

My Commission expires: _____

MORTGAGEE'S CERTIFICATE

We, the undersigned, _____ (printed name of mortgagee), mortgagee of the property shown, hereby agree to this plan of subdivision and dedicate the streets, rights-of-way, easements, and rights of access as shown to the public use forever, and hereby certify that we are the mortgagee duly authorized so to act and that said property is unencumbered by any taxes which have become due and payable.

Mortgagee (signature) _____ Date _____

NOTARY'S CERTIFICATE

State of Tennessee
County of Fayette

Before me, the undersigned, a notary public in and for the State and County aforesaid, duly commissioned and qualified, personally appeared _____ with whom I am personally acquainted and who, upon oath, acknowledged himself to be _____ with whom I am personally acquainted and who, upon oath, acknowledged himself to be _____ (title) of the _____ the within named bargainer, and that he executed the foregoing instrument for the purpose therein contained. In witness whereof, I hereunto set my hand and affix my seal this, the ____ day of _____, 20__.

Notary Public

My Commission expires: _____

SURVEYOR'S CERTIFICATE

I, _____, certify to the best of my knowledge and belief that this is a true and accurate survey of the property shown hereon; that this is a Category _____ Land Survey as defined in Title 62, Chapter 18, Tennessee Code Annotated, and that the ratio of precision is greater than or equal to 1:_____. I further certify that the survey of the lands embraced within said plat have been correctly monumented in accordance with the Subdivision Regulations of the Piperton, Tennessee.

Surveyor _____ Date _____

CERTIFICATE OF ACCURACY OF ENGINEERING AND DESIGN

I, Joshua W. Burnette, a professional Engineer, do hereby certify that the plans shown and described on hereon regarding engineering and designs governing this subdivision are true and correct, and conform to the requirements set forth in the Subdivision Regulations and other applicable requirements of the City of Piperton.

Engineer _____ Date _____



CERTIFICATE OF ADEQUACY OF STORM DRAINAGE

I, Joshua W. Burnette, do hereby certify that I am a registered Professional Engineer, and that I have designed all storm water drainage for Piperton Hills Phase 1. Neither this subdivision nor adjoining property will be damaged, nor shall the character of the land use be affected by the velocity and volume of water entering or leaving same.

Engineer _____ Date _____



CERTIFICATE OF APPROVAL OF MAJOR SUBDIVISION, CITY ENGINEER

I, _____ (printed name of signer) do hereby certify that this plat of subdivision and associated engineering design and construction documents meet the requirements of the City of Piperton's Subdivision Regulations, Technical Specifications, and Zoning Ordinance, and the specific conditions imposed on this plan of Subdivision.

City Engineer _____ Date _____

RECORDING CERTIFICATE

I, _____ (printed name of signer) do hereby certify that all required applicable development fees have been paid.

City Recorder _____ Date _____

PLANNING COMMISSION CERTIFICATE (MAJOR SUBDIVISION)

I, _____ (printed name of signer) do hereby certify that the City of Piperton Planning Commission has approved this plat of subdivision for recording.

Planning Commission Secretary _____ Date _____

CERTIFICATE OF PROPERTY ASSESSOR

Approved for Recording,

Fayette County Property Assessor _____ Date _____

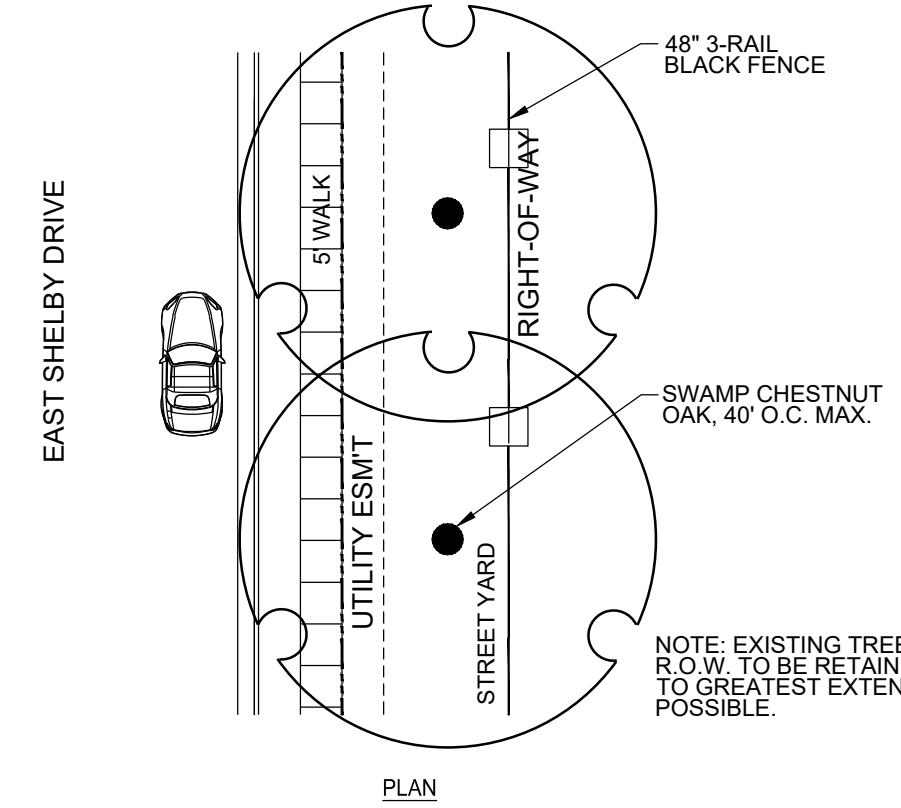
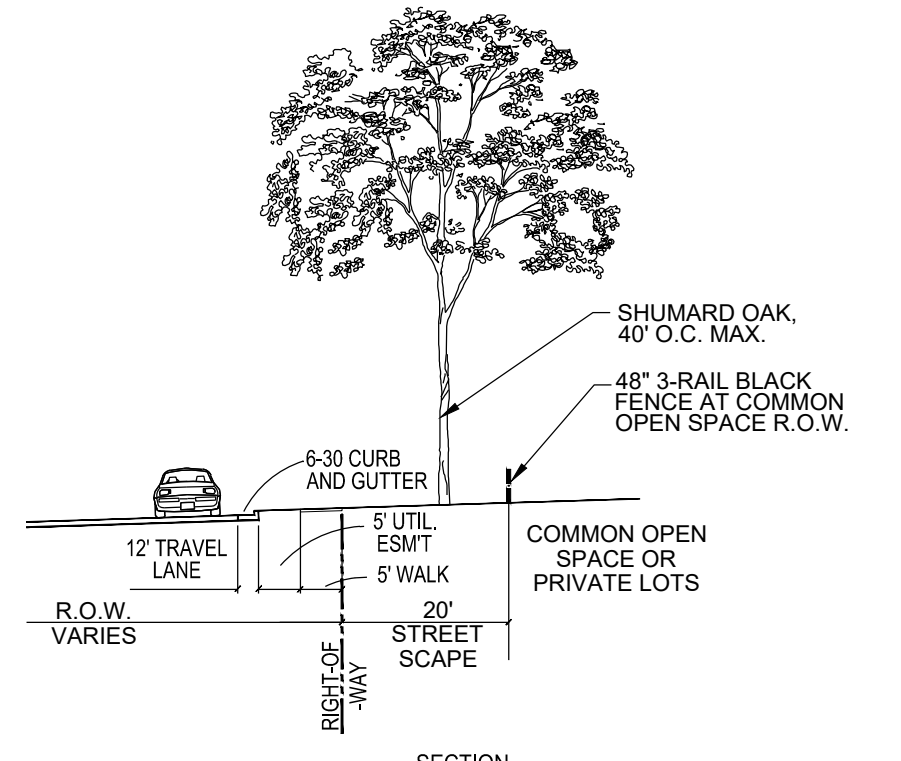

**STREETSCAPE PLATE A-1
KEOUGH DRIVE
N.T.S.**

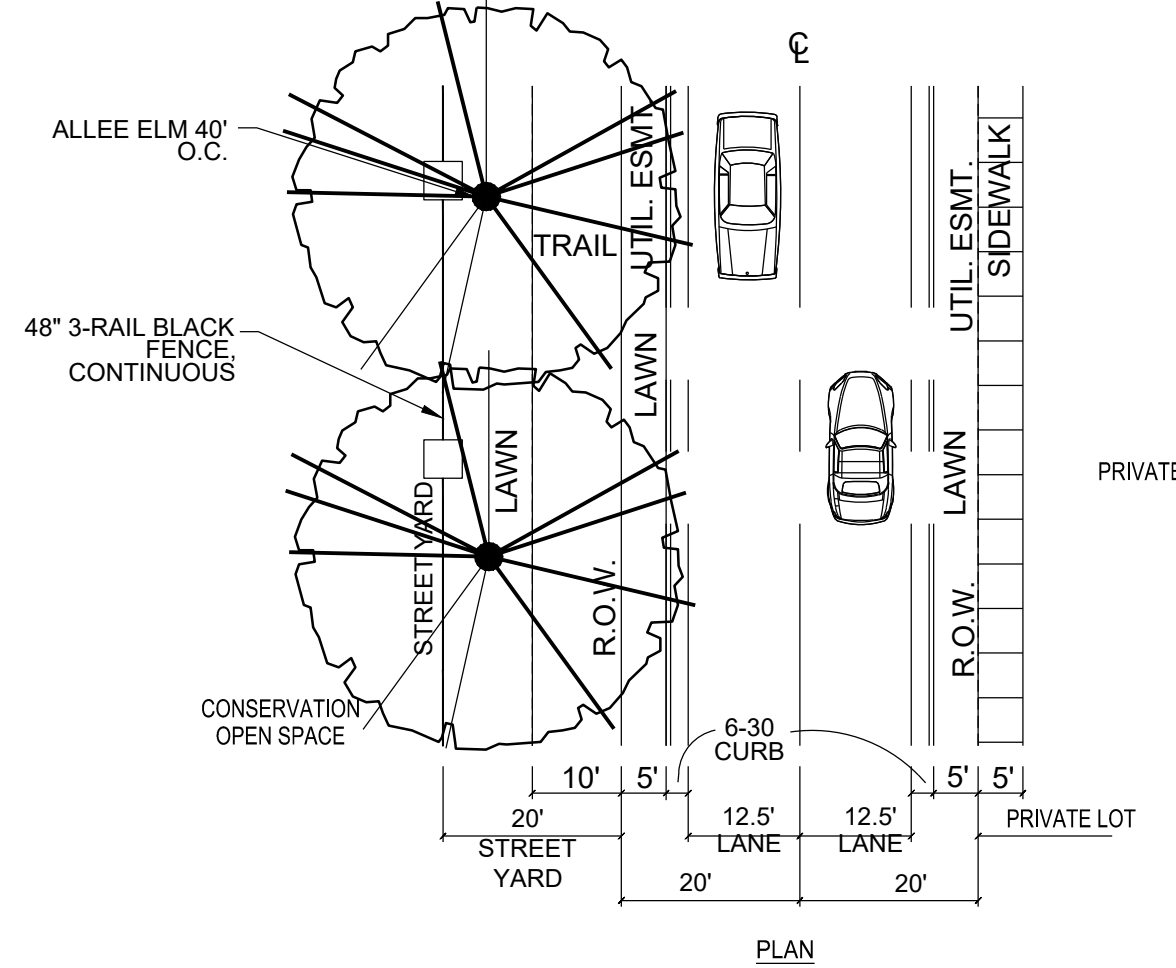
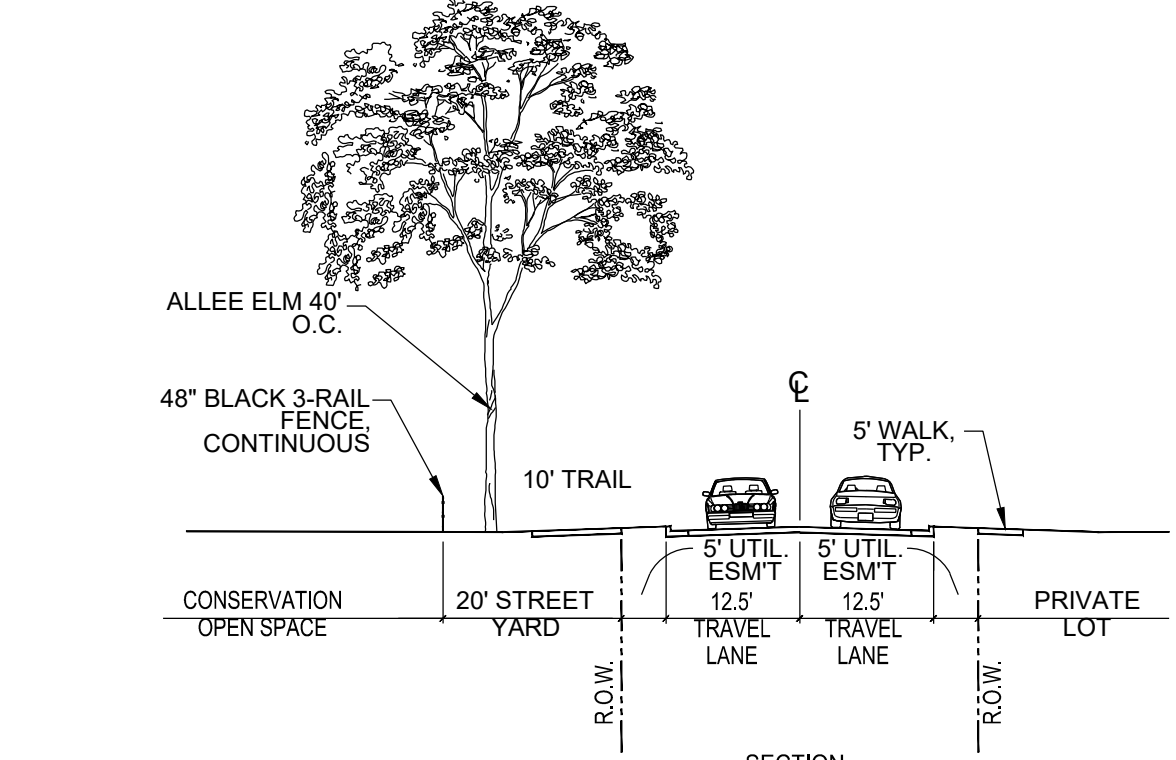

**STREETSCAPE PLATE A-4
40' R.O.W. AT COMMON OPEN SPACE
N.T.S.**

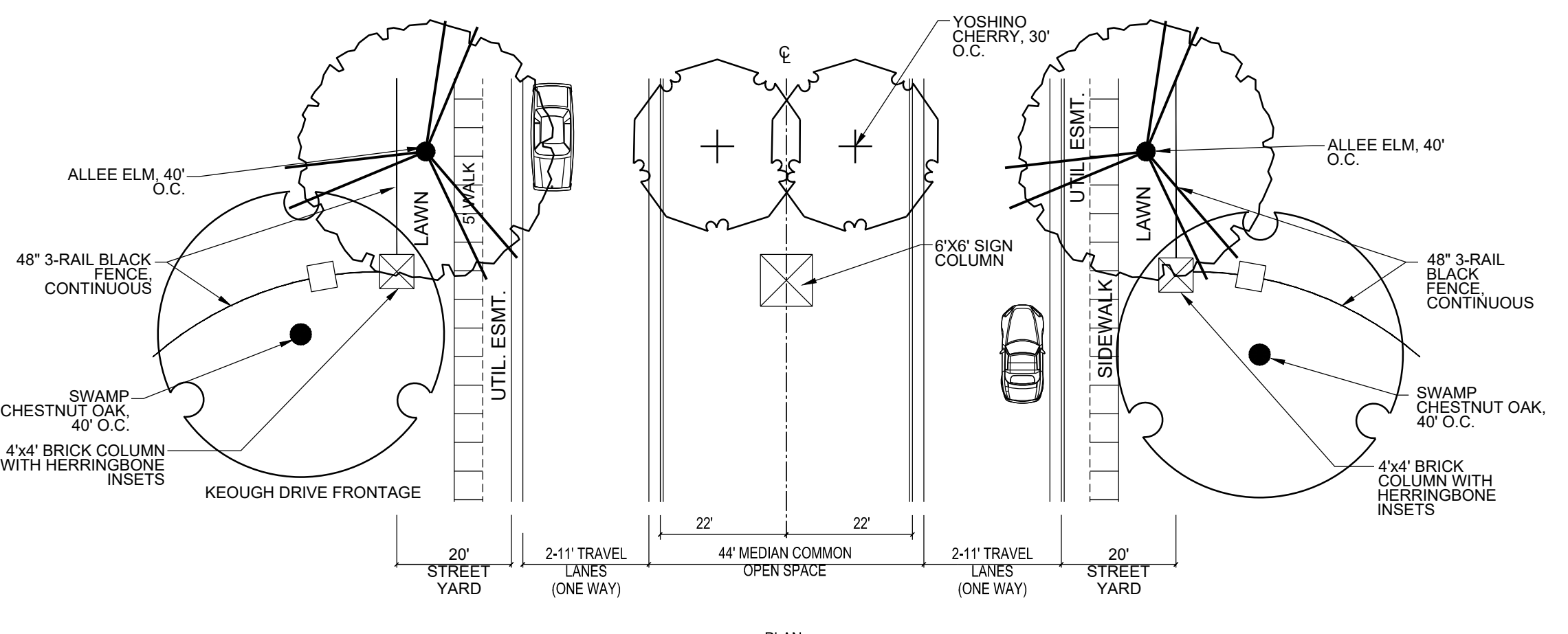
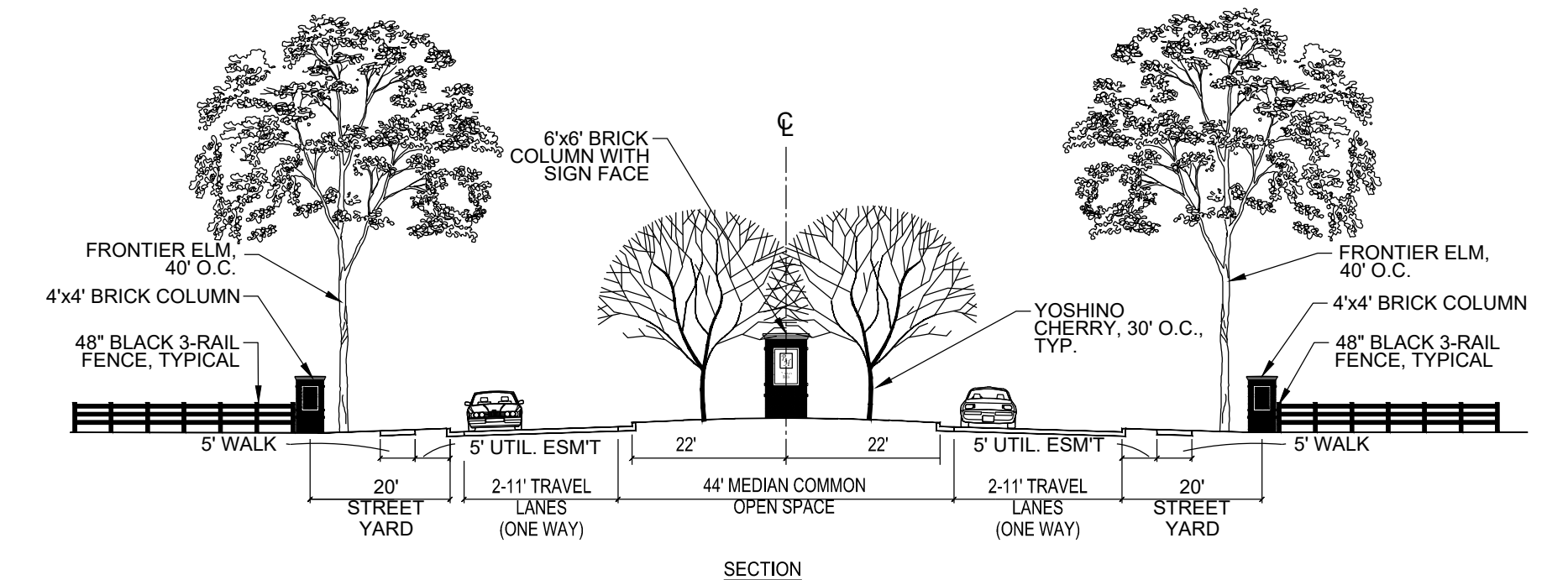

**STREETSCAPE PLATE A-3
ENTRY BOULEVARD
N.T.S.**

PRELIMINARY PLAT		
PIPERTON HILLS SUBDIVISION - PHASE 1		
PIPERTON, TENNESSEE		
PHASE 1 AREA: 32.68 AC - 31 LOTS		
ZONING: MUPD, MIXED USE PLANNED DEVELOPMENT DISTRICT		
DEVELOPER: PIPERTON HILLS PHASE 1 LLC 50 HIGHWAY 196 PIPERTON, TN 38017	ENGINEER: MCCARTY GRANBERRY ENGINEERING 198 PROGRESS ROAD COLLIERVILLE, TN 38017	RECORDED:
DATE: JANUARY 2021	SCALE: 1"=100'	SHEET 2 OF 2